

Electric Resistance Crucible Furnace

Lindberg/MPH provides robust custom equipment, including the R Series crucible furnaces. These furnaces can be adapted for a multitude of metals and built to incorporate special voltages, frequencies and temperatures.

Lindberg/MPH's furnaces can provide efficient solutions for die as well as permanent mold and sand casting of aluminum, zinc, magnesium, lead and other lower temperature melting metals. Rod-type nickelchrome elements are installed in the walls of these furnaces, allowing heat to be radiated to the container, melting the metal within. The SCR control handles the power input through use of a pyrometer and a thermocouple assembly.

Metals

- Aluminum
- Gold
- Lead
- Magnesium
- Silver
- Zinc

Lindberg/MPH can supply all the equipment necessary for your company's success

Typical additional equipment includes:

- Silicon Carbide \ Clay Graphite Crucibles
- Cast Iron Pots
- Covers lids
- Lid Lift \ Swing Systems

Features

- Minimal Metal Losses - Close control of temperature results in fewer oxides and less sludge. No gases produced that might be absorbed in the metal. These features result in low cost operation.
- Longer Crucible Or Pot Life - Placement of heating elements provides uniform distribution of heat, thus prevents localized hot spots on crucible or pot. The use of electric heat minimizes thermal shock.
- Quiet, Cool Operation - The furnace emits no sound; also, the molten metal surface radiates minimum heat. The absence of combustion and hot exhaust gases results in comfortable working conditions



Lindberg/MPH
Phone: (269) 849-2700

P.O. Box 131, 3827 Riverside Road Riverside, MI 49084
• Fax: (269) 849-3021 • lindbergmph@lindbergmph.com

www.lindbergmph.com

LINDBERG/MPH

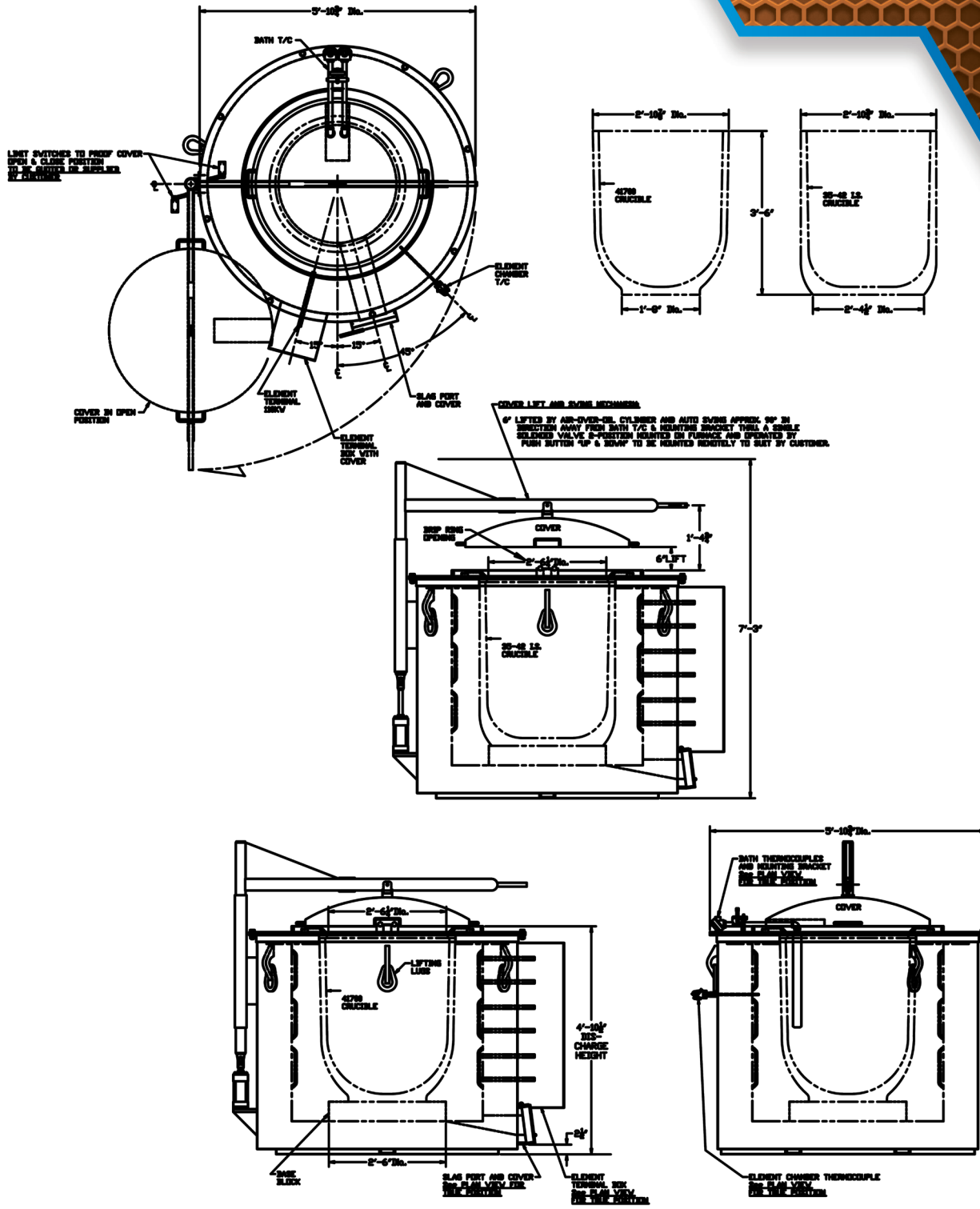

Lindberg/MPH
Phone: (269) 849-2700

P.O. Box 131, 3827 Riverside Road Riverside, MI 49084
• Fax: (269) 849-3021 • lindbergmph@indbergmph.com

www.lindbergmph.com